

Conventional Audible Visual Devices Signal Beacons

> Product Overview

KAC's conventional beacons utilise LED technology and an innovative lens design, providing Omni-directional light coverage at very low current draw. The ENscape beacon delivers outstanding quality, reliability and long operational life.



For EN54-23 approved VAD go to www.kac.co.uk/cav-conventional.html

ENscape Signal Beacon Benefits

> Simple, Fast, Flexible Installation

- Omni directional light coverage eliminates need for device orientation.
- Deep base option with multiple cable entries for flexible installation.
- Designed with full range of common fixing centres.
- Positive fit engagement and feedback of base with device for easy installation.

Outstanding Performance

- Advanced optics ensures good light coverage at low current draw.
- Red light flash.
- Soft start feature reduces power surges during system start-up.

Universal Device

- Suitable for wall and ceiling mount applications.
- Range of base options, for indoor and applications up to IP65.
- Operates on 12V and 24V systems, making the range suitable for fire & security applications.

Quality & Reliability

- Independently approved to all required standards:
 - Environmental: RoHS, WEEE

> Introducing the Range

Device	Lens Colour		Flash Colour	Environmental Compliance
	Red	Amber		
ENscape Signal Beacon	✓	✗	✓	✓
ENscape Signal Beacon	✗	✓	✓	✓

Signal Beacons – Technical Specification

Mechanical Specification

Body colour:	Red / White
Cable Terminal Size:	0.5-2.5mm ²
Material Lens:	PC
Body:	PC/ABS
Gross Weight: Standard device:	164g (low profile), 171g (deep / IP65)
First Fix option:	174g (low profile), 181g (deep / IP65)

Electrical Specification

Operating Voltage:	12 to 29VDC
Average current consumption:	3mA @ 24V

Product Performance

ENscape Signal Beacon	Wall & ceiling mount
Flash Colour	Red
Flash rate	0.5 Hz
Operating voltage range	12 to 29 V
Synchronisation	Automatically on power up

Environmental Specification

Operating Temperature:	-25°C to 70°C
Relative Humidity:	93% ±3% non condensing
Ingress Protection:	IP21C - low profile base IP65 - deep base
For RoHS, WEEE information please see www.kac.co.uk	

Dimensions

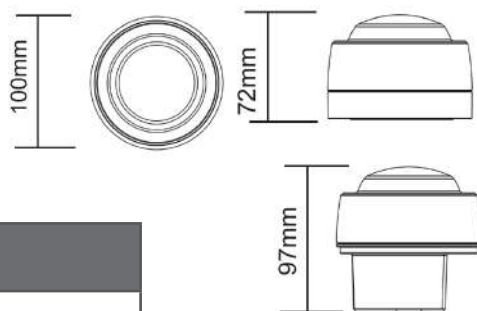

Out of Box Contents

ENscape Signal Beacon	Standard Device	Deep / IP 65 Option
Beacon including selected base	✓	✓
P pack (includes terminal block & continuity link)	✗	✗
O Ring for IP65 Sealing	✗	✓
Installation data sheet	✓	✓

Accessories:

Low Profile Bases	Deep Bases	IP and Earthing Kits
CSR – Red low profile base, pack of 5	CWR – Red deep / IP 65, pack of 5	PS189 – Deep base gasket, pack of 5
CSW – White low profile base, pack of 5	CWW – White deep / IP 65 base, pack of 5	PS188 - Deep base O Ring, pack of 5
		SC076 - Earth strap, pack of 5

Order Information:

Code	Body Colour	Flash Colour	Base Option	Install Option	Lens Colour	Example Part No.
CWST Amber Beacon	R=Red	R=Red	S=Low Profile W=IP65/Deep	7=Standard Fix	Amber Lens	CWST-RA-S7
	W=White					
CWST Red Beacon	R=Red				Red Lens	CWST-RB-S7



> KAC Alarm Company Ltd KAC House, Thornhill Road, North Moons Moat, Redditch, B98 9ND, United Kingdom
Tel: +44 (0) 1527 406655 Fax: +44 (0) 1527 406677 e-mail: marketing@kac.co.uk

We reserve the right to amend the content of this document without prior notice.