

TO TEST**TO REPLACE GLASS / RESETTABLE ELEMENT****TO RESET**

CONNECTION DETAILS WCP6A-xC01xx

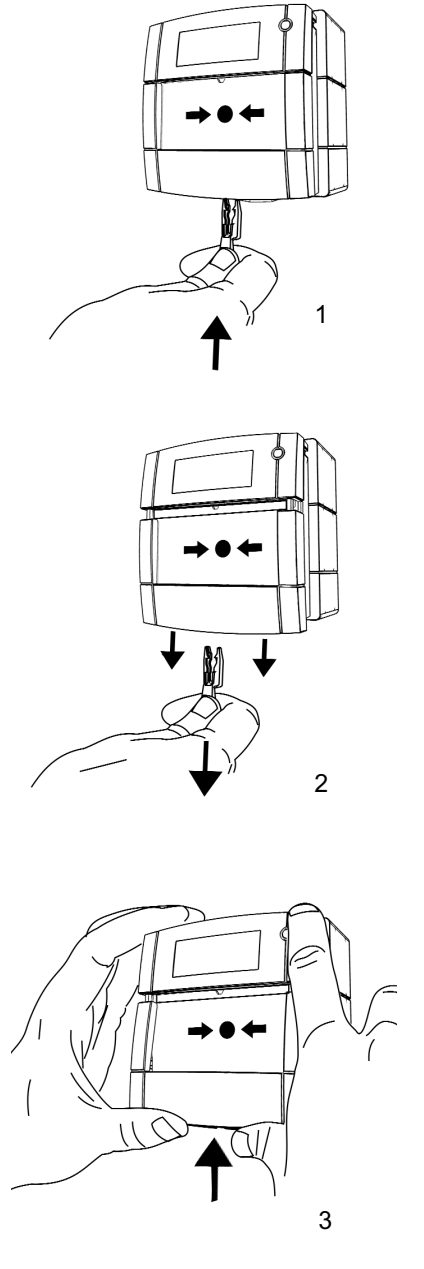
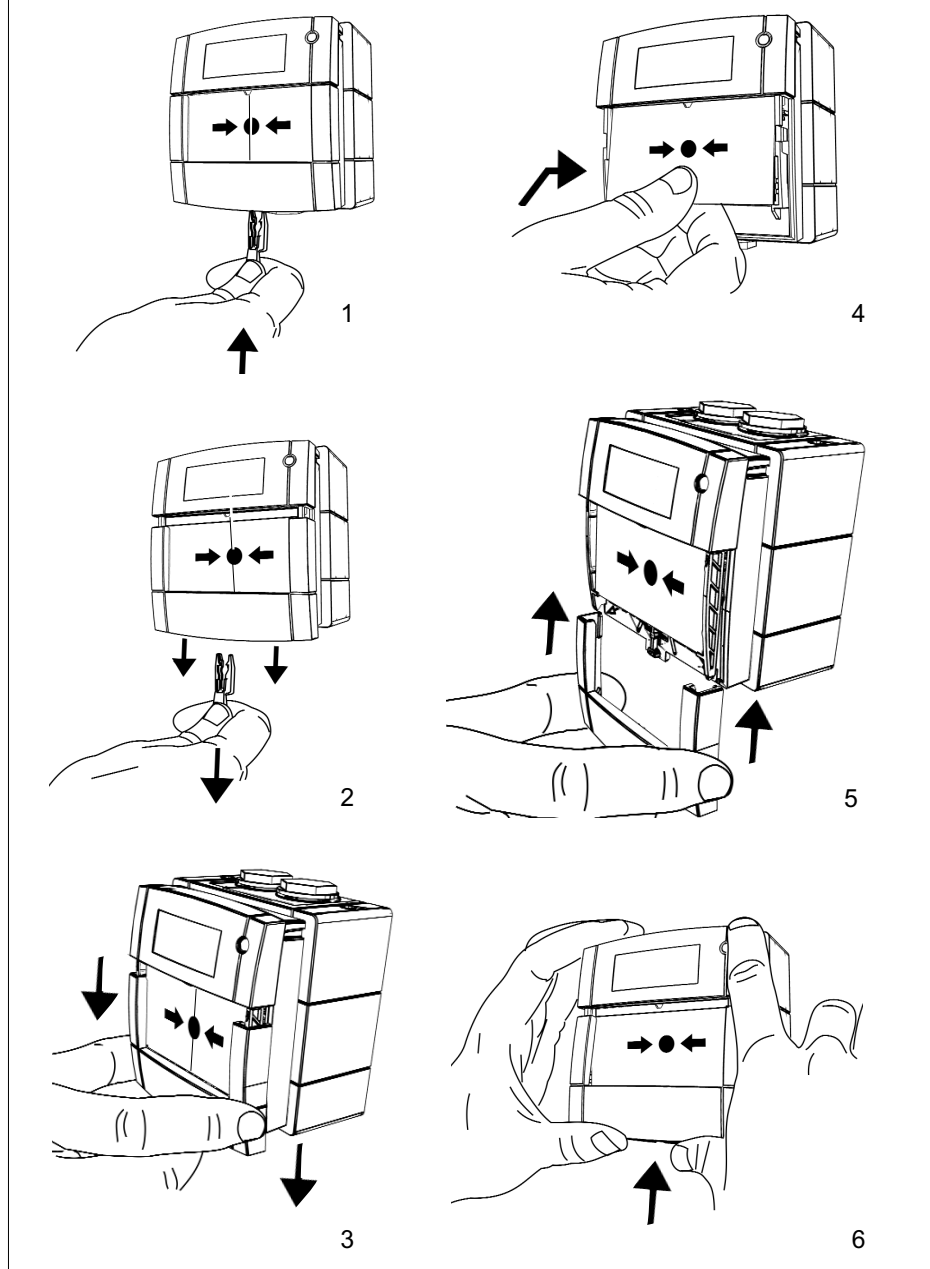
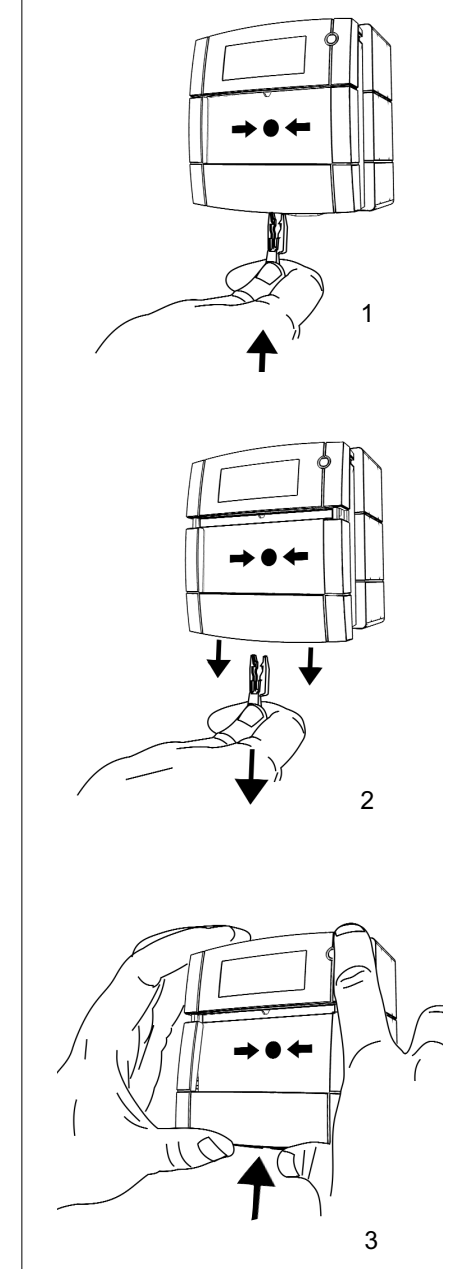
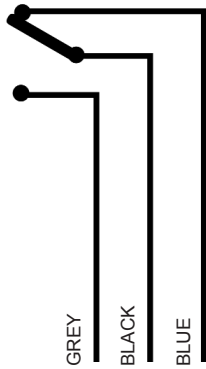

The generic part codes detailed on this data sheet contain a number of 'X' digits to cater for product variation as follows:-

Digit 6 - Product Colour
Digit 10 - Mounting (*Surface or Flush*)
Digit 11 - Element (*Glass or Reseatable*)

See WCP label for details.

DIMENSIONS

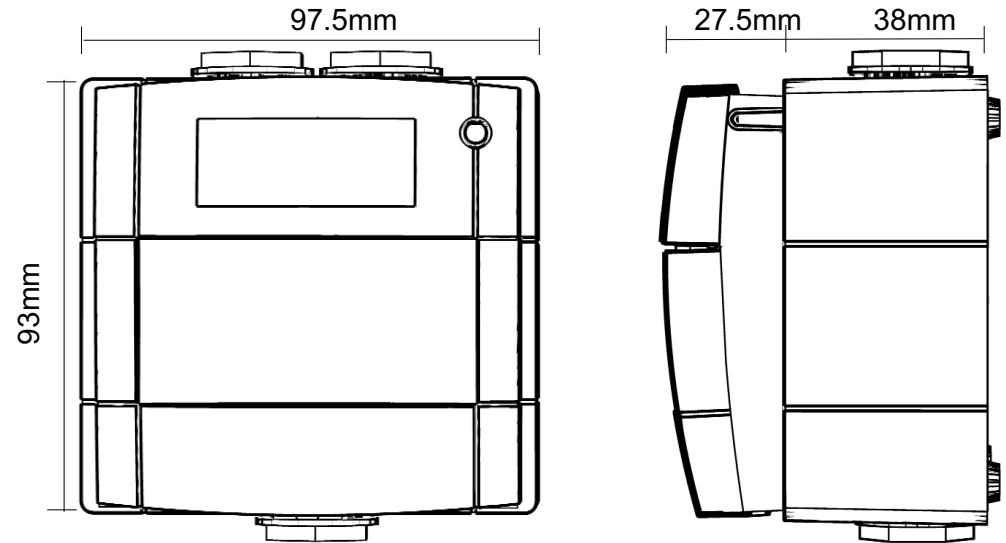

CONNECTION DETAILS WCP6B-xC01xx

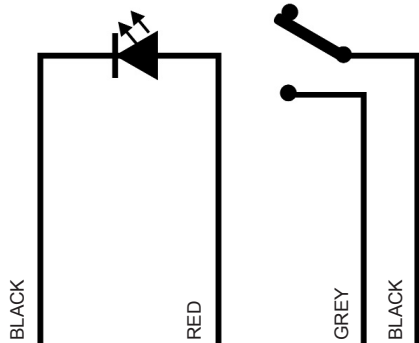

CONNECTION DETAILS WCP6B-xC02xx

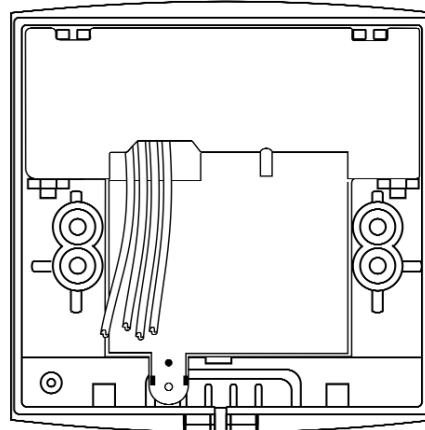
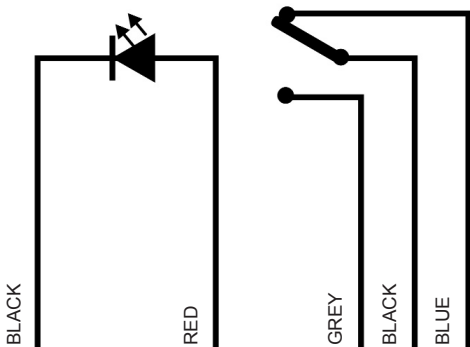

FLYING LEADS

The WCP6A and WCP6B (including variations).

WCP products are supplied with flying leads to enable connection to 3rd party PCB boards (supplied by others).

TECHNICAL DATA

30VDC Max

1.4A Max

IP67

270g

-30°C to 70°C



Red, Ral 3001
Yellow, Ral 1006
Green, Ral 6016
White, Ral 9010
Blue, Ral 5002



Important Notes; -
Please do not over tighten fixing screws.
The use of lubricants, cleaning solvents or petroleum based products should be avoided.